

PILOT-OPERATED CHECK VALVES

MODEL RD-1400 LOCK VALVE DOUBLE PILOT-OPERATED

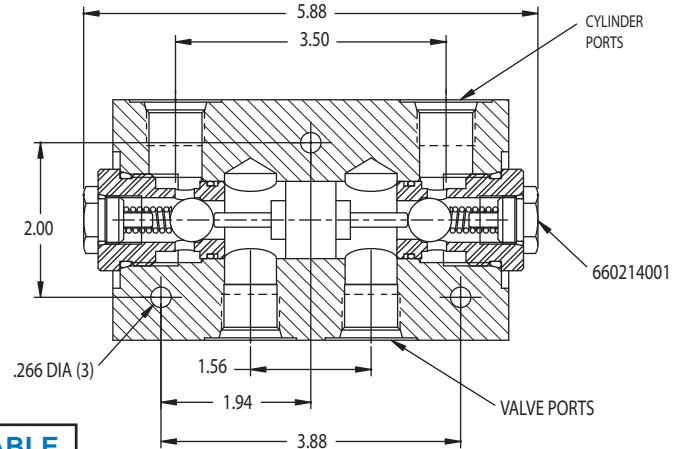
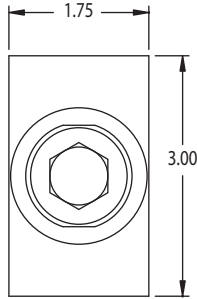
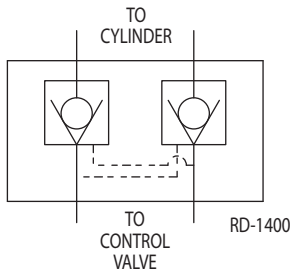

STANDARD MODELS AVAILABLE	
MODEL NUMBER	PORT SIZE
RD-1450	1/2 NPTF
RD-1475	3/4 NPTF

VALVE SPECIFICATIONS:

Capacity: 30 gpm max inlet flow
 Pressure: 3000 psi max
 Weight: 7 lbs.
 Pilot Ratio: 4:1

MODEL RD-1600 PILOT OPERATED CHECK VALVE

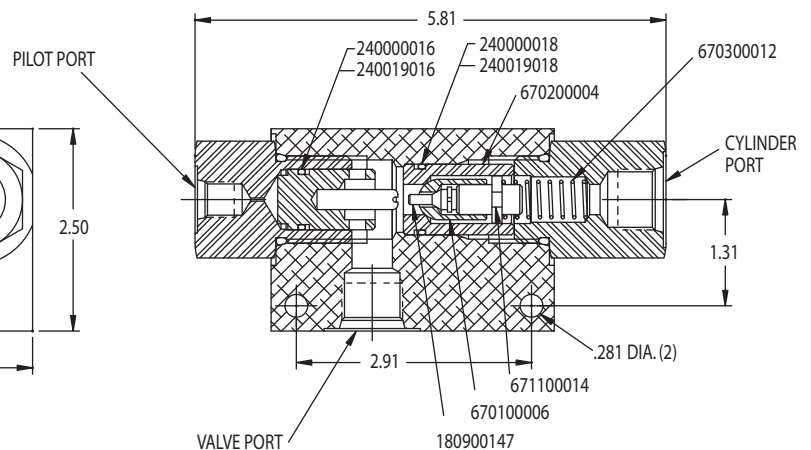
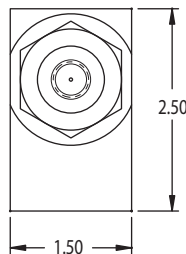
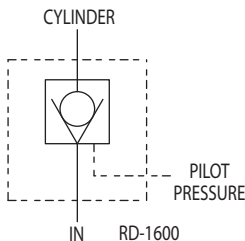

STANDARD MODELS AVAILABLE		
MODEL NUMBER	VALVE AND CYL. PORT	PILOT PORT
RD-1637	3/8 NPTF	1/4 NPTF
RD-1650	1/2 NPTF	1/4 NPTF
RD-1608	#8 SAE (3/4-16)	#4 SAE (7/16-20)

VALVE SPECIFICATIONS:

Capacity: 20 gpm max inlet flow
 Pressure: 3000 psi max
 Weight: 2 lbs.
 Pilot Ratio: 4:1
 Decompression Ratio: 16:1

VALVES