

CONSTANT VOLUME PRIORITY DIVIDERS

MODEL RD-400 FIXED FLOW PRIORITY DIVIDER



The PRINCE model RD-400 is a constant volume priority divider. It can be used in applications where two circuits are to be supplied by a single pump such as power steering systems. In operation the flow of oil supplied to the inlet is divided into two flows, the priority flow and the excess flow. The priority flow will remain nearly constant with variations in pressure on either the priority or excess flow port and will also remain nearly constant with variations in the inlet flow.

The priority flow GPM is determined by a fixed orifice inside the main spool. The desired priority GPM must be specified with model number, see below. The PRINCE model RD-400R provides the same function as described above with the addition of a built in pressure relief for the priority port only. This relief is internally adjustable and requires a separate line to tank. The relief is factory set at 1500 PSI.

VALVE SPECIFICATIONS:

Capacity: 30 gpm max inlet flow Weight: RD-400 7 lbs.
Pressure: 3000 psi max RD-400-R 7.5 lbs.

MODEL RD-400 R FIXED FLOW PRIORITY DIVIDER WITH PRIORITY PRESSURE RELIEF



STANDARD MODELS AVAILABLE				PRIORITY GPM
VALVE MODEL NUMBER		PORT SIZE		
		INLET AND EXCESS PORT	PRIORITY PORT	
RD-400-___	RD-400R-___	3/4 NPTF	3/8 NPTF	1.5
RD-405-___	RD-405R-___	3/4 NPTF	1/2 NPTF	2
RD-412-___	RD-412R-___	#12 SAE	#8 SAE	3
RD-450-___	RD-450R-___	1/2 NPTF	3/8 NPTF	4
RD-455-___	RD-455R-___	1/2 NPTF	1/2 NPTF	5
RD-477-___	RD-477R-___	3/4 NPTF	3/4 NPTF	6
				7
				8
				9
				10
				12
				14

To complete the model number fill in the blank with the desired priority GPM from the list at right.

EX: RD-400-3 for 3 GPM priority flow; RD-405R-6 for 6 GPM priority flow.

MODEL RD-500 ADJUSTABLE FLOW PRIORITY DIVIDER



The PRINCE model RD-500 is an adjustable constant volume priority divider. This valve provides the same function as the PRINCE model RD-400 except the priority flow is adjustable from 2 GPM to 12 GPM. The priority flow is set using the adjusting screw and is then locked in place to maintain setting. This allows setting to be fine tuned in the field to the exact flow needed.

VALVE SPECIFICATIONS

Capacity: 30 gpm max inlet flow
Pressure: 3000 psi max
Weight: 7 lbs.

STANDARD MODELS AVAILABLE	
VALVE MODEL NUMBER	PORT SIZE
RD-537	3/8 NPTF
RD-550	1/2 NPTF
RD-575	3/4 NPTF

MODEL RD-400, RD-400R AND RD-500 PARTS BREAKDOWN AND DIMENSIONS

RD-400

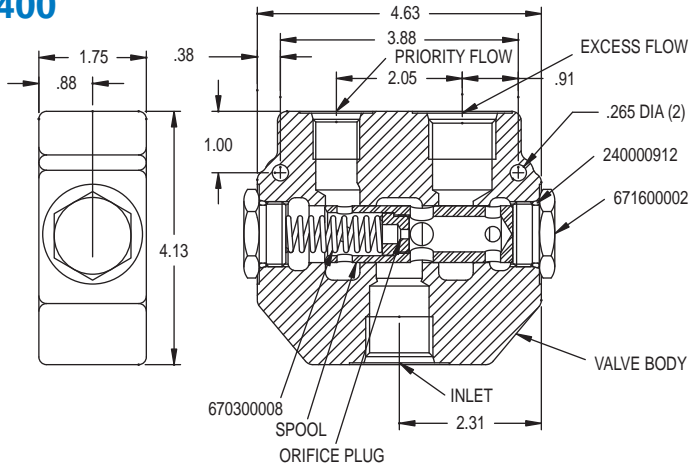

SYMBOL

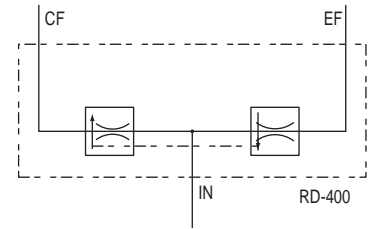

SEAL KIT NO. 660504001

RD-400R

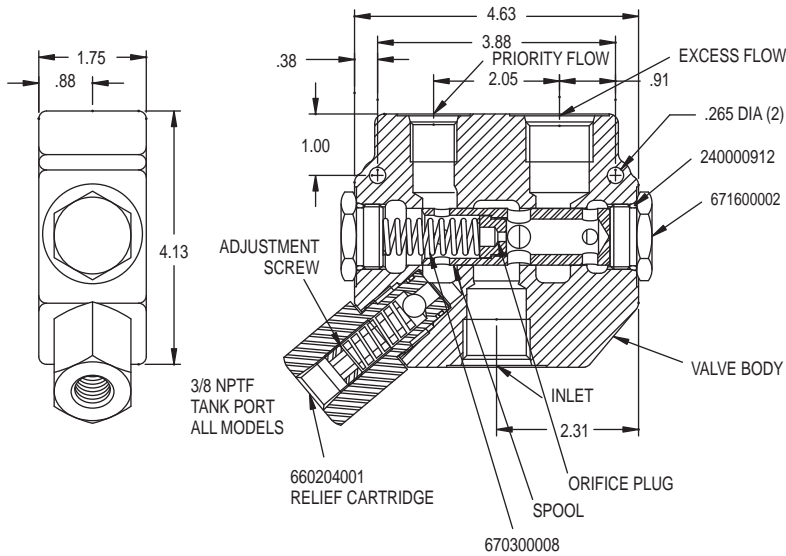

SYMBOL

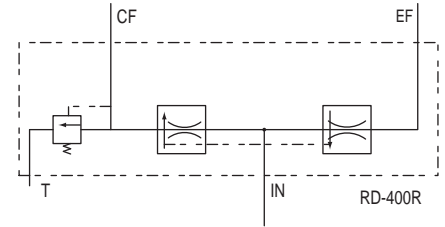

SEAL KIT NO. 660504002

RD-500

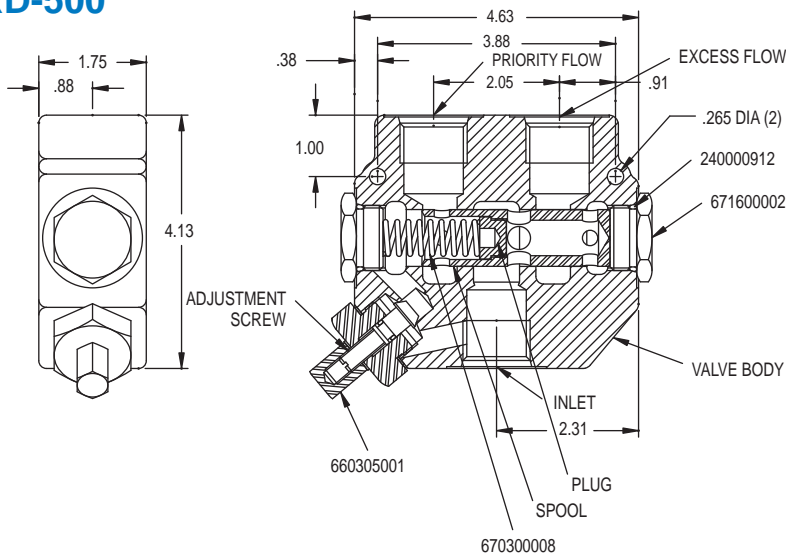

SYMBOL

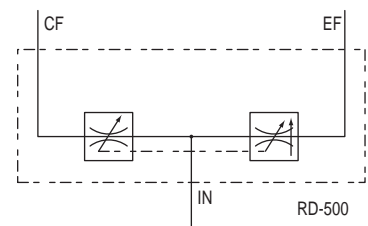

SEAL KIT NO. 660505001

NOTE: spools are not available separately