



V A L V E S

Adjustable Flow Control Valves



The PRINCE valve model W-1900 is a pressure compensated adjustable flow control valve. By rotating the handle, the flow out the "CF" or controlled flow port can be varied within the range given in the chart below. Any remaining flow is bypassed to the "EF" or excess flow port. This flow can be used to power another circuit or can be returned to tank. Once the controlled flow is set, it will remain nearly constant with variations in pressure on either the controlled or excess flow ports. Please note, if during operation the controlled flow port is blocked, the valve will compensate in such a way as to shut off flow to the excess port.

This valve can also be used as a restrictive flow control by plugging the excess flow port.

The PRINCE valve model WR-1900 has a built in adjustable pressure relief. For this model, the excess flow port **must** be connected to tank. It should be noted that whenever these or any valve is used to bypass or restrict flow, heat will be generated. Steps may be required to keep oil temperature from becoming too high.

Model W/WR Adjustable Flow Control Valves

MODEL No.	DESCRIPTION	CROSS REF.	WEIGHT (POUNDS)	LIST PRICE
W-1950-8	½-NPTF PORTS (0-8 GPM CF SPOOL)	FC51-½ 37	9	89.00
W-1908-8	#8 SAE/ORB PORTS (0-8 GPM CF SPOOL)	FC51-8	9	89.00
W-1950-16	½-NPTF PORTS (0-16 GPM CF SPOOL)	FC51-½	9	89.00
W-1975-30	¾-NPTF PORTS (0-30-GPM CF SPOOL)	FC51-3/4	9	89.00
W-1912-30	#12 SAE/ORB PORTS (0-30 GPM CF SPOOL)	FC51-12	9	89.00
WR-1950-16	½-NPTF PORTS (0-16 GPM W/RELIEF)	FCR51-½	9	96.50
WR-1975-30	¾ NPTF PORTS (0-30 GPM W/RELIEF)	FCR51-¾	9	96.50

RELIEF PRESSURE INFORMATION:

Inlet relief protection available on "WR" models. Relief pressure preset at 1500 PSI. To adjust, remove acorn nut, turn adjusting screw clockwise to increase pressure, counterclockwise to reduce pressure. Reinstall acorn nut after adjusting. Use a pressure gauge when making adjustments.

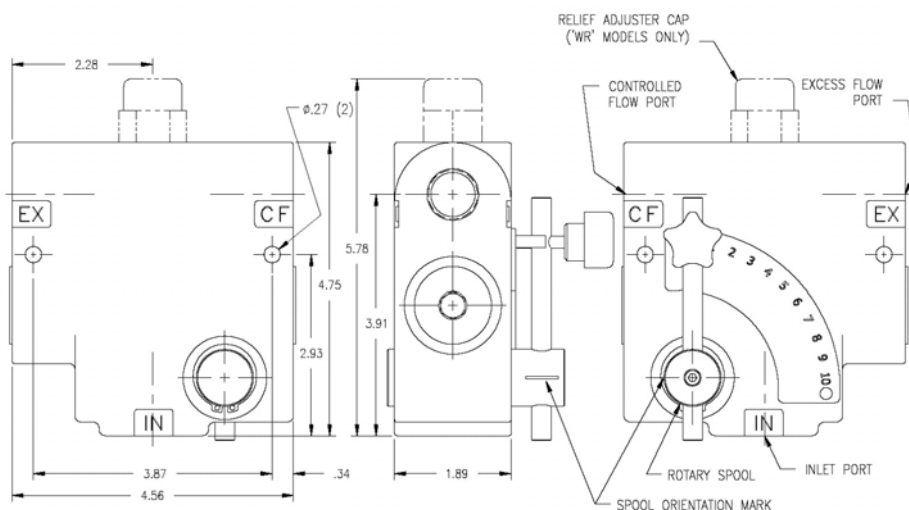

NOTE: ALL DIMENSIONS ARE FOR REFERENCE ONLY.

VALVE SPECIFICATIONS

- 30 GPM max flow
- 3000 PSI max
- 180° F max temp
- Filtration 17/14/19
- For use with mineral based hydraulic fluid
- Side port configuration
- 100% Tested
- External seals on rotary spool prevent contamination from locking up spool

KITS

PART NO.	DESCRIPTION	LIST
660170064	HANDLE KIT	7.60
660570004	SEAL KIT	4.90